

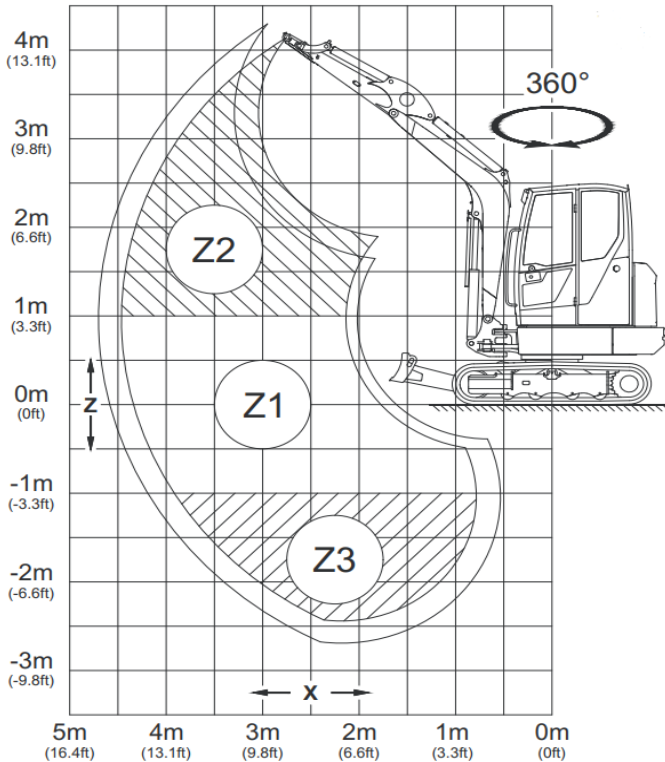

Hubkrafttabellen ET42



Alle Tabellenwerte sind in kg (lbs) angegeben, bei waagrechtcr Stellung auf festem Untergrund und ohne Löffel.

Sofern ein Löffel oder sonstige Arbeitsgeräte angebaut sind, verringert sich die Hubkraft oder Kipplast um deren Eigengewicht.



Berechnungsgrundlage: gemäß ISO 10567

Die Hubkraft des Baggers ist durch die Einstellung der Überdruckventile und durch die Kippsicherheit begrenzt.

Es werden weder 75% der statischen Kipplast noch 87% der hydraulischen Hubkraft überschritten.

Die Hubkraft gilt für Fahrzeuge unter folgenden Bedingungen:

- Schmier- und Betriebsmittel auf den vorgeschriebenen Ständen
- Voller Kraftstofftank
- Kabine
- Fahrzeug auf Betriebstemperatur
- Gewicht des Fahrers 75kg (165lbs)

max	Zulässige Last bei gestrecktem Löffelstiel
A	Ausladung von mitte Drehkranz
B	Lasthakenhöhe
*	Hubkraft durch Hydraulik begrenzt
	Mit bzw. ohne Planierschildabstützung in Fahrtrichtung
	Ohne Planierschildabstützung 90° zur Fahrtrichtung



Hubkrafttabellen ET42

					4,0 m (13'-1'')			3,0 m (9'-10'')			2,0 m (6'-7'')		
A	B												
		Schild Unten	Schild oben		Schild Unten	Schild oben		Schild Unten	Schild oben		Schild Unten	Schild oben	
4,0 m (13'-1'')		973* (2.145)*	973* (2.145)*	962 (2.120)	-	-	-	920* (2.029)*	920* (2.029)*	920* (2.029)*	-	-	-
3,0 m (9'-10'')		930* (2.051)*	734 (1.617)	672 (1.481)	917* (2.023)*	775 (1.710)	710 (1.566)	-	-	-	-	-	-
2,0 m (6'-7'')		935* (2.062)*	622 (1.372)	570 (1.257)	971* (2.141)*	761 (1.677)	696 (1.534)	1.155* (2.547)*	1.155* (2.547)*	1.076 (2.373)	1.736* (3.827)*	1.736* (3.827)*	1.736* (3.827)*
1,0 m (3'-3'')		957* (2.111)*	586 (1.291)	536 (1.182)	1.091* (2.407)*	733 (1.617)	669 (1.476)	1.508* (3.324)*	1.117 (2.462)	1.007 (2.221)	-	-	-
0,0 m (0'-0'')		987* (2.177)*	602 (1.328)	550 (1.213)	1.165* (2.568)*	713 (1.571)	649 (1.431)	1.696* (3.740)*	1.072 (2.363)	964 (2.126)	3.025* (6.669)*	2.052 (4.524)	1.779 (3.923)
- 1,0 m (-3'-3'')		1.013* (2.233)*	690 (1.522)	629 (1.388)	1.067* (2.352)*	711 (1.568)	648 (1.428)	1.620* (3.573)*	1.063 (2.345)	956 (2.108)	2.666* (5.878)*	2.065 (4.553)	1.792 (3.950)
- 2,0 m (-6'-7'')		980* (2.160)*	980* (2.160)*	890 (1.962)	-	-	-	1.151* (2.537)*	1.092 (2.407)	983 (2.168)	-	-	-

Tab. 1: Hubkrafttabelle ET42-STD ohne Zusatzgewicht, Gummikette, kurzer Löffelstiel

					4,0 m (13'-1'')			3,0 m (9'-10'')			2,0 m (6'-7'')		
A	B												
		Schild Unten	Schild oben		Schild Unten	Schild oben		Schild Unten	Schild oben		Schild Unten	Schild oben	
4,0 m (13'-1'')		889* (1.960)*	889* (1.960)*	844 (1.862)	-	-	-	-	-	-	-	-	-
3,0 m (9'-10'')		864* (1.904)*	673 (1.483)	616 (1.358)	836* (1.844)*	777 (1.714)	711 (1.569)	-	-	-	-	-	-
2,0 m (6'-7'')		873* (1.924)*	577 (1.273)	529 (1.166)	910* (2.007)*	758 (1.672)	693 (1.528)	1.054 (2.324)*	1.054* (2.324)*	1.054* (2.324)*	-	-	-
1,0 m (3'-3'')		896* (1.976)*	545 (1.202)	498 (1.099)	1.046* (2.307)*	729 (1.607)	664 (1.464)	1.427* (3.148)*	1.118 (2.465)	1.008 (2.222)	-	-	-
0,0 m (0'-0'')		927* (2.044)*	558 (1.231)	510 (1.124)	1.145* (2.524)*	704 (1.552)	640 (1.412)	1.663* (3.667)*	1.064 (2.347)	956 (2.109)	3.065* (6.759)*	2.035 (4.486)	1.763 (3.886)
- 1,0 m (-3'-3'')		957* (2.110)*	631 (1.391)	575 (1.267)	1.102* (2.431)*	697 (1.537)	633 (1.397)	1.643* (3.623)*	1.049 (2.313)	942 (2.076)	2.788* (6.149)*	2.039 (4.495)	1.766 (3.895)
- 2,0 m (-6'-7'')		952* (2.100)*	854 (1.882)	774 (1.706)	-	-	-	1.288* (2.840)*	1.069 (2.356)	961 (2.118)	2.104* (4.640)*	2.082 (4.591)	1.806 (3.982)

Tab. 2: Hubkrafttabelle ET42-STD ohne Zusatzgewicht, Gummikette, langer Löffelstiel



Hubkrafttabellen ET42

					4,0 m (13'-1")			3,0 m (9'-10")			2,0 m (6'-7")		
A	B												
		Schild Unten	Schild oben	Schild oben	Schild Unten	Schild oben	Schild oben	Schild Unten	Schild oben	Schild oben	Schild Unten	Schild oben	Schild oben
4,0 m (13'-1")		973* (2.145)*	973* (2.145)*	973* (2.145)*	-	-	-	920* (2.029)*	920* (2.029)*	920* (2.029)*	-	-	-
3,0 m (9'-10")		930* (2.051)*	833 (1.838)	765 (1.686)	917* (2.023)*	880 (1.940)	806 (1.778)	-	-	-	-	-	-
2,0 m (6'-7")		935* (2.062)*	711 (1.568)	653 (1.439)	971* (2.141)*	865 (1.907)	792 (1.746)	1.155* (2.547)*	1.155* (2.547)*	1.155* (2.547)*	1.736* (3.827)*	1.736* (3.827)*	1.736* (3.827)*
1,0 m (3'-3")		957* (2.111)*	672 (1.481)	616 (1.359)	1.091* (2.407)*	838 (1.847)	766 (1.688)	1.508* (3.324)*	1.270 (2.800)	1.147 (2.529)	-	-	-
0,0 m (0'-0")		987* (2.177)*	691 (1.524)	633 (1.396)	1.165* (2.568)*	817 (1.801)	745 (1.644)	1.696* (3.740)*	1.225 (2.700)	1.104 (2.434)	3.025* (6.669)*	2.339 (5.158)	2.032 (4.481)
- 1,0 m (-3'-3")		1.013* (2.233)*	791 (1.745)	723 (1.594)	1.067* (2.352)*	815 (1.798)	744 (1.641)	1.620* (3.573)*	1.216 (2.682)	1.096 (2.416)	2.666* (5.878)*	2.353 (5.188)	2.045 (4.508)
- 2,0 m (-6'-7")		980* (2.160)*	980 (2.160)	980* (2.160)*	-	-	-	1.151* (2.537)*	1.151* (2.537)*	1.123* (2.476)*	-	-	-

Tab.3: Hubkrafttabelle ET42-STD mit Zusatzgewicht, Gummikette, kurzer Löffelstiel

					4,0 m (13'-1")			3,0 m (9'-10")			2,0 m (6'-7")		
A	B												
		Schild Unten	Schild oben	Schild oben	Schild Unten	Schild oben	Schild oben	Schild Unten	Schild oben	Schild oben	Schild Unten	Schild oben	Schild oben
4,0 m (13'-1")		889* (1.960)*	889* (1.960)*	889* (1.960)*	-	-	-	-	-	-	-	-	-
3,0 m (9'-10")		864* (1.904)*	766 (1.690)	703 (1.550)	836* (1.844)*	836* (1.844)*	808 (1.781)	-	-	-	-	-	-
2,0 m (6'-7")		873* (1.924)*	662 (1.459)	607 (1.339)	910* (2.007)*	863 (1.334)	790 (1.741)	1.054* (2.324)*	1.054* (2.324)*	1.054* (2.324)*	-	-	-
1,0 m (3'-3")		896* (1.976)*	627 (1.382)	575 (1.267)	1.046* (2.307)*	833 (1.836)	761 (1.677)	1.427* (3.148)*	1.271 (2.802)	1.147 (2.530)	-	-	-
0,0 m (0'-0")		927* (2.044)*	643 (1.417)	588 (1.298)	1.145* (2.524)*	808 (1.782)	737 (1.624)	1.663* (3.667)*	1.217 (2.684)	1.096 (2.417)	3.065* (6.759)*	2.322 (5.121)	2.016 (4.444)
- 1,0 m (-3'-3")		957* (2.110)*	725 (1.600)	663 (1.461)	1.102* (2.431)*	801 (1.766)	730 (1.609)	1.643* (6.623)*	1.202 (2.650)	1.081 (2.384)	2.788* (6.149)*	2.326 (5.129)	2.019 (4.453)
- 2,0 m (-6'-7")		952* (2.100)*	952* (2.100)*	887 (1.956)	-	-	-	1.288* (2.840)*	1.222 (2.694)	1.100 (2.426)	2.104* (4.640)*	2.104* (4.640)*	2.059 (4.540)

Tab.4: Hubkrafttabelle ET42-STD mit Zusatzgewicht, Gummikette, langer Löffelstiel



Hubkrafttabellen ET42

					4,0 m (13'-1'')			3,0 m (9'-10'')			2,0 m (6'-7'')		
A	B												
		Schild Unten	Schild oben		Schild Unten	Schild oben		Schild Unten	Schild oben		Schild Unten	Schild oben	
4,0 m (13'-1'')		973* (2.145)*	973* (2.145)*	949 (2.092)	- -	- -	- -	920* (2.029)*	920* (2.029)*	920* (2.029)*	- -	- -	- -
3,0 m (9'-10'')		930* (2.051)*	749 (1.651)	664 (1.465)	917* (2.023)*	791 (1.745)	702 (1.548)	- -	- -	- -	- -	- -	- -
2,0 m (6'-7'')		935* (2.062)*	636 (1.402)	564 (1.244)	971* (2.141)*	776 (1.712)	688 (1.516)	1.155* (2.547)*	1.155* (2.547)*	1.061* (2.339)*	1.736* (3.827)*	1.736* (3.827)*	1.736* (3.827)*
1,0 m (3'-3'')		957* (2.111)*	599 (1.321)	530 (1.170)	1.091* (2.407)*	749 (1.652)	661 (1.459)	1.508* (3.324)*	1.139 (2.511)	992 (2.187)	- -	- -	- -
0,0 m (0'-0'')		987* (2.177)*	616 (1.359)	544 (1.200)	1.165* (2.568)*	729 (1.607)	641 (1.414)	1.696* (3.740)*	1.094 (2.412)	949 (2.094)	3.025* (6.669)*	2.087 (4.602)	1.736 (3.829)
-1,0 m (-3'-3'')		1.013* (2.233)*	706 (1.557)	622 (1.372)	1.067* (2.352)*	727 (1.604)	640 (1.412)	1.620* (3.573)*	1.086 (2.394)	942 (2.076)	2.666* (5.878)*	2.100 (4.631)	1.748 (3.855)
-2,0 m (-6'-7'')		980* (2.160)*	980* (2.160)*	877 (1.934)	- -	- -	- -	1.151* (2.537)*	1.114 (2.456)	968 (2.135)	- -	- -	- -

Tab.5: Hubkrafttabelle ET42-STD ohne Zusatzgewicht, Stahlkette, kurzer Löffelstiel

					4,0 m (13'-1'')			3,0 m (9'-10'')			2,0 m (6'-7'')		
A	B												
		Schild Unten	Schild oben		Schild Unten	Schild oben		Schild Unten	Schild oben		Schild Unten	Schild oben	
4,0 m (13'-1'')		889* (1.960)*	889* (1.960)*	834 (1.839)	- -	- -	- -	- -	- -	- -	- -	- -	- -
3,0 m (9'-10'')		864* (1.904)*	687 (1.515)	609 (1.344)	836* (1.844)*	793 (1.749)	703 (1.551)	- -	- -	- -	- -	- -	- -
2,0 m (6'-7'')		873* (1.924)*	591 (1.302)	523 (1.154)	910* (2.007)*	774 (1.708)	685 (1.511)	1.054* (2.324)*	1.054* (2.324)*	1.054* (2.324)*	- -	- -	- -
1,0 m (3'-3'')		896* (1.976)*	558 (1.230)	493 (1.088)	1.046 (2.307)*	745 (1.642)	656 (1.447)	1.427* (3.148)*	1.140 (2.513)	992 (2.188)	- -	- -	- -
0,0 m (0'-0'')		927* (2.044)*	571 (1.260)	504 (1.112)	1.145* (2.524)*	720 (1.588)	633 (1.395)	1.663* (3.667)*	1.086 (2.396)	942 (2.076)	3.065* (6.759)*	2.070 (4.564)	1.720 (3.792)
-1,0 m (-3'-3'')		957* (2.110)*	646 (1.423)	568 (1.253)	1.102* (2.431)*	713 (1.572)	626 (1.380)	1.643* (3.623)*	1.071 (2.362)	927 (2.045)	2.788* (6.149)*	2.074 (4.573)	1.723 (3.800)
-2,0 m (-6'-7'')		952* (2.100)*	872 (1.923)	764 (1.684)	- -	- -	- -	1.288* (2.840)*	1.091 (2.405)	946 (2.086)	2.104* (4.640)*	2.104* (4.640)*	1.762 (3.886)

Tab.6: Hubkrafttabelle ET42-STD ohne Zusatzgewicht, Stahlkette, langer Löffelstiel



Hubkrafttabellen ET42

					4,0 m (13'-1'')			3,0 m (9'-10'')			2,0 m (6'-7'')		
A	B												
		Schild Unten	Schild oben		Schild Unten	Schild oben		Schild Unten	Schild oben		Schild Unten	Schild oben	
4,0 m (13'-1'')		973* (2.145)*	973* (2.145)*	973* (2.145)*	-	-	-	920* (2.029)*	920* (2.029)*	920* (2.029)*	-	-	-
3,0 m (9'-10'')		930* (2.051)*	848 (1.870)	755 (1.665)	917* (2.023)*	895 (1.973)	796 (1.756)	-	-	-	-	-	-
2,0 m (6'-7'')		935* (2.062)*	724 (1.597)	645 (1.422)	971* (2.141)*	880 (1.940)	782 (1.724)	1.155* (2.547)*	1.155* (2.547)*	1.155* (2.547)*	1.736* (3.827)*	1.736* (3.827)*	1.736* (3.827)*
1,0 m (3'-3'')		957* (2.111)*	685 (1.510)	609 (1.343)	1.091* (2.407)*	853 (1.881)	756 (1.667)	1.508* (3.324)*	1.291 (2.846)	1.128 (2.488)	-	-	-
0,0 m (0'-0'')		987* (2.177)*	705 (1.554)	626 (1.380)	1.165* (2.568)*	832 (1.835)	736 (1.623)	1.696* (3.740)*	1.246 (2.747)	1.086 (2.394)	3.025* (6.669)*	2.372 (5.230)	1.981 (4.368)
- 1,0 m - (3'-3'')		1.013* (2.233)*	806 (1.778)	714 (1.574)	1.067* (2.352)*	831 (1.832)	735 (1.620)	1.620* (3.573)*	1.237 (2.729)	1.078 (2.377)	2.666* (5.878)*	2.385 (5.259)	1.993 (4.395)
- 2,0 m - (6'-7'')		980* (2.160)*	980* (2.160)*	980* (2.160)*	-	-	-	1.151* (2.537)*	1.151* (2.537)*	1.105 (2.436)	-	-	-

Tab.7: Hubkrafttabelle ET42-STD mit Zusatzgewicht, Stahlkette, kurzer Löffelstiel

					4,0 m (13'-1'')			3,0 m (9'-10'')			2,0 m (6'-7'')		
A	B												
		Schild Unten	Schild oben		Schild Unten	Schild oben		Schild Unten	Schild oben		Schild Unten	Schild oben	
4,0 m (13'-1'')		889* (1.960)*	889* (1.960)*	889* (1.960)*	-	-	-	-	-	-	-	-	-
3,0 m (9'-10'')		864* (1.904)*	780 (1.721)	695 (1.532)	836* (1.844)*	836* (1.844)*	798 (1.759)	-	-	-	-	-	-
2,0 m (6'-7'')		873* (1.924)*	675 (1.487)	600 (1.324)	910* (2.007)*	878 (1.936)	780 (1.719)	1.054* (2.324)*	1.054* (2.324)*	1.054* (2.324)*	-	-	-
1,0 m (3'-3'')		896* (1.976)*	639 (1.410)	568 (1.253)	1.046* (2.307)*	848 (1.870)	751 (1.656)	1.427* (3.148)*	1.292 (2.848)	1.129 (2.489)	-	-	-
0,0 m (0'-0'')		927* (2.044)*	656 (1.446)	582 (1.282)	1.145* (2.524)*	823 (1.816)	727 (1.603)	1.663* (3.667)*	1.238 (2.730)	1.078 (2.377)	3.065* (6.759)*	2.355 (5.192)	1.964 (4.331)
- 1,0 m - (3'-3'')		957* (2.110)*	740 (1.631)	654 (1.443)	1.102* (2.431)*	816 (1.800)	720 (1.588)	1.643* (3.623)*	1.223 (2.697)	1.064 (2.345)	2.788* (6.149)*	2.359 (5.201)	1.968 (4.339)
- 2,0 m - (6'-7'')		952* (2.100)*	952* (2.100)*	874 (1.928)	-	-	-	1.288* (2.840)*	1.243 (2.740)	1.082 (2.386)	2.104* (4.640)*	2.104* (4.640)*	2.007 (4.425)

Tab.8: Hubkrafttabelle ET42-STD mit Zusatzgewicht, Stahlkette, langer Löffelstiel



Hubkrafttabellen ET42

					4,0 m (13'-1")			3,0 m (9'-10")			2,0 m (6'-7")		
A	B												
		Schild Unten	Schild oben		Schild Unten	Schild oben		Schild Unten	Schild oben		Schild Unten	Schild oben	
4,0 m (13'-1")		973* (2.145)*	973* (2.145)*	973* (2.145)*	-	-	-	920* (2.029)*	920* (2.029)*	920* (2.029)*	-	-	-
3,0 m (9'-10")		930* (2.051)*	722 (1.592)	692 (1.525)	917* (2.023)*	763 (1.684)	731 (1.611)	-	-	-	-	-	-
2,0 m (6'-7")		935* (2.062)*	612 (1.349)	588 (1.296)	971* (2.141)*	749 (1.651)	716 (1.579)	1.155* (2.547)*	1.155* (2.547)*	1.106 (2.439)	1.736* (3.827)*	1.736* (3.827)*	1.736* (3.827)*
1,0 m (3'-3")		957* (2.111)*	576 (1.269)	553 (1.220)	1.091* (2.407)*	721 (1.591)	690 (1.521)	1.508* (3.324)*	1.099 (2.423)	1.037 (2.286)	-	-	-
0,0 m (0'-0")		987* (2.177)*	592 (1.305)	568 (1.252)	1.165* (2.568)*	701 (1.545)	670 (1.476)	1.696* (3.740)*	1.054 (2.324)	994 (2.191)	3.025* (6.669)*	2.019 (4.451)	1.833 (4.042)
-1,0 m (-3'-3")		1.013* (2.233)*	679 (1.497)	649 (1.432)	1.067* (2.352)*	699 (1.542)	668 (1.474)	1.620* (3.573)*	1.046 (2.306)	986 (2.174)	2.666* (5.878)*	2.032 (4.480)	1.845 (4.069)
-2,0 m (-6'-7")		980* (2.160)*	968 (2.134)	917 (2.021)	-	-	-	1.151* (2.537)*	1.074 (2.368)	1.013 (2.234)	-	-	-

Tab.9: Hubkrafttabelle ET42-schwenkbares Planierschild, ohne Zusatzgewicht, Gummikette, kurzer Löffelstiel

					4,0 m (13'-1")			3,0 m (9'-10")			2,0 m (6'-7")		
A	B												
		Schild Unten	Schild oben		Schild Unten	Schild oben		Schild Unten	Schild oben		Schild Unten	Schild oben	
4,0 m (13'-1")		889* (1.960)*	889* (1.960)*	868 (1.914)	-	-	-	-	-	-	-	-	-
3,0 m (9'-10")		864* (1.904)*	662 (1.459)	635 (1.399)	836* (1.844)*	765 (1.687)	732 (1.614)	-	-	-	-	-	-
2,0 m (6'-7")		873* (1.924)*	568 (1.252)	545 (1.203)	910* (2.007)*	746 (1.646)	714 (1.574)	1.054* (2.324)*	1.054* (2.324)*	1.054* (2.324)*	-	-	-
1,0 m (3'-3")		896* (1.976)*	536 (1.181)	515 (1.135)	1.046* (2.307)*	717 (1.580)	685 (1.510)	1.427* (3.148)*	1.100 (2.426)	1.037 (2.287)	-	-	-
0,0 m (0'-0")		927* (2.044)*	548 (1.209)	526 (1.161)	1.145* (2.524)*	692 (1.526)	661 (1.457)	1.663* (3.667)*	1.047 (2.308)	986 (2.174)	3.065* (6.759)*	2.001 (4.413)	1.816 (4.005)
-1,0 m (-3'-3")		957* (2.110)*	620 (1.367)	593 (1.309)	1.102* (2.431)*	685 (1.510)	654 (1.442)	1.643* (3.623)*	1.031 (2.274)	971 (2.142)	2.788* (6.149)*	2.005 (4.422)	1.820 (4.013)
-2,0 m (-6'-7")		952* (2.100)*	840 (1.851)	798 (1.759)	-	-	-	1.288* (2.840)*	1.051 (2.318)	990 (2.184)	2.104* (4.640)*	2.049 (4.517)	1.860 (4.101)

Tab.10: Hubkrafttabelle ET42-schwenkbares Planierschild, ohne Zusatzgewicht, Gummikette, langer Löffelstiel



Hubkrafttabellen ET42

					4,0 m (13'-1")			3,0 m (9'-10")			2,0 m (6'-7")		
A	B												
		Schild Unten	Schild oben		Schild Unten	Schild oben		Schild Unten	Schild oben		Schild Unten	Schild oben	
4,0 m (13'-1")		973* (2.145)*	973* (2.145)*	973* (2.145)*	-	-	-	920* (2.029)*	920* (2.029)*	920* (2.029)*	-	-	-
3,0 m (9'-10")		930* (2.051)*	822 (1.812)	784 (1.729)	917* (2.023)*	868 (1.913)	827 (1.824)	-	-	-	-	-	-
2,0 m (6'-7")		935* (2.062)*	701 (1.545)	670 (1.478)	971* (2.141)*	853 (1.880)	813 (1.792)	1.155* (2.547)*	1.155* (2.547)*	1.155* (2.547)*	1.739* (3.827)*	1.739* (3.827)*	1.739* (3.827)*
1,0 m (3'-3")		957* (2.111)*	662 (1.459)	633 (1.396)	1.091* (2.407)*	826 (1.820)	786 (1.734)	1.508* (3.324)*	1.252 (2.761)	1.176 (2.594)	-	-	-
0,0 m (0'-0")		987* (2.177)*	681 (1.502)	651 (1.435)	1.165* (2.568)*	805 (1.774)	766 (1.689)	1.696* (3.740)*	1.207 (2.661)	1.133 (2.499)	3.025* (6.669)*	2.306 (5.085)	2.086 (4.600)
- 1,0 m -(3'-3")		1.013* (2.233)*	780 (1.719)	743 (1.638)	1.067* (2.352)*	803 (1.771)	765 (1.686)	1.620* (3.573)*	1.199 (2.643)	1.125 (2.482)	2.666* (5.878)*	2.319 (5.114)	2.098 (4.627)
- 2,0 m -(6'-7")		980* (2.160)*	980* (2.160)*	980* (2.160)*	-	-	-	1.151* (2.537)*	1.151* (2.537)*	1.151* (2.537)*	-	-	-

Tab. 11: Hubkrafttabelle ET42-schwenkbare Planierschild, mit Zusatzgewicht, Gummikette, kurzer Löffelstiel

					4,0 m (13'-1")			3,0 m (9'-10")			2,0 m (6'-7")		
A	B												
		Schild Unten	Schild oben		Schild Unten	Schild oben		Schild Unten	Schild oben		Schild Unten	Schild oben	
4,0 m (13'-1")		889* (1.960)*	889* (1.960)*	889* (1.960)*	-	-	-	-	-	-	-	-	-
3,0 m (9'-10")		864* (1.904)*	756 (1.666)	722 (1.591)	836* (1.844)*	836* (1.844)*	828 (1.827)	-	-	-	-	-	-
2,0 m (6'-7")		873* (1.924)*	652 (1.438)	624 (1.376)	910* (2.007)*	851 (1.876)*	810 (1.786)	1.054* (2.324)*	1.054* (2.324)*	1.054* (2.324)*	-	-	-
1,0 m (3'-3")		896* (1.976)*	617 (1.362)	591 (1.303)	1.046* (2.307)*	821 (1.810)	781 (1.722)	1.427* (3.148)*	1.253 (2.763)	1.177 (2.595)	-	-	-
0,0 m (0'-0")		927* (2.044)*	633 (1.396)	605 (1.335)	1.145* (2.524)*	796 (1.755)	757 (1.670)	1.663* (3.667)*	1.199 (2.645)	1.126 (2.482)	3.065* (6.759)*	2.289 (5.047)	2.069 (4.563)
- 1,0 m -(3'-3")		957* (2.110)*	714 (1.575)	681 (1.502)	1.102* (2.431)*	789 (1.740)	750 (1.655)	1.643* (3.623)*	1.184 (2.611)	1.111 (2.450)	2.788* (6.149)*	2.293 (5.056)	2.073 (4.571)
- 2,0 m -(6'-7")		952* (2.100)*	952* (2.100)*	911 (2.009)	-	-	-	1.288* (2.840)*	1.204 (2.655)	1.130 (2.492)	2.104* (4.640)*	2.104* (4.640)*	2.104* (4.640)*

Tab. 12: Hubkrafttabelle ET42-schwenkbare Planierschild, mit Zusatzgewicht, Gummikette, langer Löffelstiel



Hubkrafttabellen ET42

					4,0 m (13'-1")			3,0 m (9'-10")			2,0 m (6'-7")		
A	B												
		Schild Unten	Schild oben		Schild Unten	Schild oben		Schild Unten	Schild oben		Schild Unten	Schild oben	
4,0 m (13'-1")		973* (2.145)*	973* (2.145)*	973* (2.145)*	-	-	-	920* (2.029)*	920* (2.029)*	920* (2.029)*	-	-	-
3,0 m (9'-10")		930* (2.051)*	737 (1.625)	683 (1.507)	917* (2.023)*	779 (1.718)	722 (1.591)	-	-	-	-	-	-
2,0 m (6'-7")		9359* (2.062)*	626 (1.379)	581 (1.281)	971* (2.141)*	764 (1.685)	707 (1.560)	1.155* (2.547)*	1.155* (2.547)*	1.089 (2.401)	1.736* (3.827)*	1.736* (3.827)*	1.736* (3.827)*
1,0 m (3'-3")		957* (2.111)*	589 (1.299)	547 (1.206)	1.091* (2.407)*	737 (1.626)	681 (1.502)	1.508* (3.324)*	1.121 (2.472)	1.020 (2.250)	-	-	-
0,0 m (0'-0")		987* (2.177)*	606 (1.335)	561 (1.238)	1.165* (2.568)*	716 (1.580)	661 (1.458)	1.696* (3.740)*	1.076 (2.373)	978 (2.156)	3.025* (6.669)*	2.053 (4.528)	1.787 (3.941)
-1,0 m (-3'-3")		1.013* (2.233)*	694 (1.531)	641 (1.414)	1.067* (2.352)*	715 (1.577)	660 (1.455)	1.620* (3.573)*	1.068 (2.354)	970 (2.139)	2.666* (5.878)*	2.067 (4.557)	1.799 (3.968)
-2,0 m (-6'-7")		980* (2.160)*	980* (2.160)*	903 (1.991)	-	-	-	1.151* (2.537)*	1.096 (2.417)	997 (2.198)	-	-	-

Tab. 13: Hubkrafttabelle ET42-schwenkbare Planierschild, ohne Zusatzgewicht, Stahlkette, kurzer Löffelstiel

					4,0 m (13'-1")			3,0 m (9'-10")			2,0 m (6'-7")		
A	B												
		Schild Unten	Schild oben		Schild Unten	Schild oben		Schild Unten	Schild oben		Schild Unten	Schild oben	
4,0 m (13'-1")		889* (1.960)*	889* (1.960)*	856 (1.888)	-	-	-	-	-	-	-	-	-
3,0 m (9'-10")		864* (1.904)*	676 (1.491)	627 (1.383)	836* (1.844)*	781 (1.722)	723 (1.594)	-	-	-	-	-	-
2,0 m (6'-7")		873* (1.924)*	581 (1.281)	539 (1.189)	910* (2.007)*	762 (1.681)	705 (1.554)	1.054* (2.324)*	1.054* (2.324)*	1.054* (2.324)*	-	-	-
1,0 m (3'-3")		896* (1.976)*	548 (1.209)	509 (1.122)	1.046* (2.307)*	732 (1.615)	676 (1.491)	1.427* (3.148)*	1.122 (2.474)	1.021 (2.251)	-	-	-
0,0 m (0'-0")		927* (2.044)*	561 (1.238)	520 (1.147)	1.145* (2.524)*	708 (1.561)	652 (1.438)	1.663* (3.667)*	1.069 (2.356)	970 (2.139)	3.065* (6.759)*	2.036 (4.490)	1.771 (3.904)
-1,0 m (-3'-3")		957* (2.110)*	634 (1.399)	586 (1.293)	1.102* (2.431)*	701 (1.545)	646 (1.423)	1.643* (3.623)*	1.053 (2.323)	956 (2.107)	2.788* (6.149)*	2.040 (4.499)	1.774 (3.912)
-2,0 m (-6'-7")		952* (2.100)*	858 (1.891)	787 (1.734)	-	-	-	1.288* (2.840)*	1.073 (2.366)	974 (2.148)	2.104* (4.640)*	2.083 (4.594)	1.813 (3.998)

Tab. 14: Hubkrafttabelle ET42-schwenkbare Planierschild, ohne Zusatzgewicht, Stahlkette, langer Löffelstiel



Hubkrafttabellen ET42

					4,0 m (13'-1")			3,0 m (9'-10")			2,0 m (6'-7")		
A	B												
		Schild Unten	Schild oben		Schild Unten	Schild oben		Schild Unten	Schild oben		Schild Unten	Schild oben	
4,0 m (13'-1")		973* (2.145)*	973* (2.145)*	973* (2.145)*	-	-	-	920* (2.029)*	920* (2.029)*	920* (2.029)*	-	-	-
3,0 m (9'-10")		930* (2.051)*	837 (1.845)	774 (1.707)	917* (2.023)*	883 (1.946)	816 (1.800)	-	-	-	-	-	-
2,0 m (6'-7")		935* (2.062)*	714 (1.574)	662 (1.460)	971* (2.141)*	868 (1.914)	802 (1.768)	1.155* (2.547)*	1.155* (2.547)*	1.155* (2.547)*	1.736* (3.827)*	1.736* (3.827)*	1.736* (3.827)*
1,0 m (3'-3")		957* (2.111)*	675 (1.488)	625 (1.379)	1.091* (2.407)*	841 (1.854)	776 (1.710)	1.508* (3.324)*	1.273 (2.806)	1.157 (2.551)	-	-	-
0,0 m (0'-0")		987* (2.177)*	694 (1.531)	643 (1.417)	1.165* (2.568)*	820 (1.808)	756 (1.666)	1.696* (3.740)*	1.228 (2.708)	1.114 (2.457)	3.025* (6.669)*	2.338 (5.156)	2.032 (4.481)
-1,0 m (-3'-3")		1.013* (2.233)*	795 (1.752)	733 (1.616)	1.067* (2.352)*	819 (1.805)	754 (1.663)	1.620* (3.573)*	1.220 (2.689)	1.106 (2.439)	2.666* (5.878)*	2.351 (5.185)	2.044 (4.507)
-2,0 m (-6'-7")		980* (2.160)*	980* (2.160)*	980* (2.160)*	-	-	-	1.151* (2.537)*	1.151* (2.537)*	1.133 (2.499)	-	-	-

Tab. 15: Hubkrafttabelle ET42-schwenkbare Planierschild, mit Zusatzgewicht, Stahlkette, kurzer Löffelstiel

					4,0 m (13'-1")			3,0 m (9'-10")			2,0 m (6'-7")		
A	B												
		Schild Unten	Schild oben		Schild Unten	Schild oben		Schild Unten	Schild oben		Schild Unten	Schild oben	
4,0 m (13'-1")		889* (1.960)*	889* (1.960)*	889* (1.960)*	-	-	-	-	-	-	-	-	-
3,0 m (9'-10")		864* (1.904)*	769 (1.697)	712 (1.571)	836* (1.844)*	836* (1.844)*	817 (1.802)	-	-	-	-	-	-
2,0 m (6'-7")		873* (1.924)*	665 (1.466)	616 (1.359)	910* (2.007)*	866 (1.909)	799 (1.762)	1.054* (2.324)*	1.054* (2.324)*	1.054* (2.324)*	-	-	-
1,0 m (3'-3")		896* (1.976)*	630 (1.389)	584 (1.287)	1.046* (2.307)*	836 (1.843)	771 (1.699)	1.427* (3.148)*	1.274 (2.809)	1.157 (2.551)	-	-	-
0,0 m (0'-0")		927* (2.044)*	646 (1.424)	598 (1.318)	1.145* (2.524)*	811 (1.789)	747 (1.647)	1.663* (3.667)*	1.220 (2.691)	1.106 (2.440)	3.065* (6.759)*	2.321 (5.118)	2.015 (4.444)
-1,0 m (-3'-3")		957* (2.110)*	729 (1.606)	672 (1.483)	1.102* (2.431)*	804 (1.773)	740 (1.632)	1.643* (3.623)*	1.205 (2.658)	1.092 (2.408)	2.788* (6.149)*	2.325 (5.127)	2.019 (4.452)
-2,0 m (-6'-7")		952* (2.100)*	952* (2.100)*	897 (1.979)	-	-	-	1.288* (2.840)*	1.225 (2.701)	1.111 (2.449)	2.104* (4.640)*	2.104* (4.640)*	2.058 (4.538)

Tab. 16: Hubkrafttabelle ET42-schwenkbare Planierschild, mit Zusatzgewicht, Stahlkette, langer Löffelstiel